



- High Accuracy
- Broad Bandwidth
- Low Zero-drift

Shenzhen Hangzhi Precision Electronics Co. Ltd.

HIT200 Hall-Substituting Current Transducer

HIT200 has a high gain and measurement accuracy in the full bandwidth range, due to the application of the multi-point zero-flux technology system and high-frequency ripple sensing channel on top of currently existing DC sensor technology.

The multi-point zero-flux technology system secures the high accuracy by utilizing the technology combination of exciting magnetic flux closed-loop control, self-excited magnetic flux gate and multi-closed-loop control that realizes the closed-loop control between excitation magnetic flux and AC/DC magnetic flux generated by primary current, while the high-frequency ripple sensing channel allows the sensor to have the high performance over the full bandwidth range.

Product photo

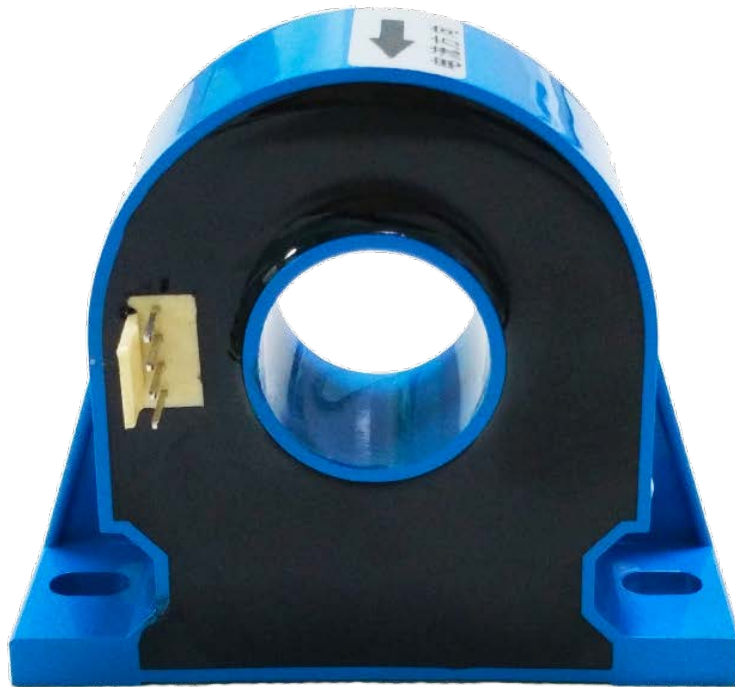

SHENZHEN HANGZHI PRECISION ELECTRONICS CO. LTD

Add: Rm 531, Building B, Huayuan Hi-Tech Innovation Park,
Baoyuan Road, Bao'an District, Shenzhen, China P.R.
Email: sales@hangzhicn.com Technical support: info@hangzhicn.com
Tel: +86(0)755-8259 3440 Website: www.hangzhicn.com



- High Accuracy
- Broad Bandwidth
- Low Zero-drift

Shenzhen Hangzhi Precision Electronics Co. Ltd.

Key Technologies

- ◇ Excitation closed-loop control technology
- ◇ Self-excitation demagnetization technology
- ◇ Multi-point zero-flux technology
- ◇ Temperature control compensation technology
- ◇ Multi-range automatic switching technology

Features

- ◇ Insulated measurement between primary and secondary side
- ◇ Excellent linearity and accuracy
- ◇ Extremely low temperature drift
- ◇ Extremely low zero drift
- ◇ Broad bandwidth and short response time
- ◇ Strong anti-electromagnetic interference

Application Domain

- ◇ Medical Equipment: Scanner, MRI
- ◇ Power industry: Converter, Inverter □
- ◇ Renewable Energy: Photovoltaic, Wind energy □
- ◇ Testing Instrument: Power analyzer, High-precision power supply
- ◇ Smart Power Grid: Power generation and battery monitoring, Medium low voltage substation
- ◇ Industry Control: Industrial motor drive, UPS, Welding, Robot, Hoist, Elevator, Ski lift
- ◇ Rail Transit: EMU, Metro, Trolley car □
- ◇ Ship: Electric driven ship
- ◇ Car: Electric car

Electrical Performance

Parameter	Symbol	Measuring Conditions	Min	Typ	Max	Unit
Primary nominal direct current	I_{PN_DC}	—	—	±200	—	Adc
Primary nominal RMS current*	I_{PN_AC}	—	—	141	—	Aac
Primary current, measuring range	I_{PM}	—	—	—	±240	Adc
Power supply voltage DC	U_C	—	±14.2	±15	±15.8	V
Current consumption	I_C	Rated primary current	±30	±130	±150	mA
Conversion ratio	K_N	Primary/secondary	1:2000	1:2000	1:2000	—
Secondary nominal RMS current	I_{SN}	Rated primary current	—	±0.1	—	A
Secondary burden resistance	R_M	—	0	10	25	Ω

* refers to AC effective value



- High Accuracy
- Broad Bandwidth
- Low Zero-drift

Shenzhen Hangzhi Precision Electronics Co. Ltd.

Accuracy Measurement

Parameter	Symbol	Measuring Conditions	Min	Typ	Max	Unit
Accuracy	X_G	Input direct current, full temperature range	—	—	500	ppm
Linearity error	ε_L	Full scale	—	—	50	ppm
Offset temperature coefficient	T_C	—	—	—	50	ppm/K
Zero offset current	I_0	@25°C	—	—	±5	μA
Zero offset current	I_{OT}	Full temperature range	—	—	±10	μA
Step response time to 90% I_{PN_DC}	t_r	di/dt of 100A/μs	—	1	—	μs
di/dt accurately followed	di/dt	—	100	—	—	A/μs
Frequency bandwidth (-3dB)	BW	—	0	—	100	kHz

Safety Characteristics

Parameter	Symbol	Measuring Conditions	Value	Unit
Insulation voltage / Between primary and secondary	U_d	50Hz, 1min	5	KV
Impulse withstand voltage / Between primary and secondary	U_w	50μs	10	KV
Creepage distance / Between primary and shield	d_{CP}	—	11	mm
Clearance distance / Between primary and shield	d_{CI}	—	11	mm
Comparative tracking index	CTI	IEC-60112	275	V

General Characteristics

Parameter	Symbol	Measuring Condition	Min	Typ	Max	Unit
Ambient operating temperature	T_A	—	-40	—	+80	°C
Storage temperature range	T_s	—	-55	—	+95	°C
Relative humidity	RH	—	20	—	80	%
Mass	M	—	—	85±10	—	g

SHENZHEN HANGZHI PRECISION ELECTRONICS CO. LTD

Add: Rm 531, Building B, Huayuan Hi-Tech Innovation Park,
Baoyuan Road, Bao'an District, Shenzhen, China P.R.
Email: sales@hangzhicn.com Technical support: info@hangzhicn.com
Tel: +86(0)755-8259 3440 Website: www.hangzhicn.com



- High Accuracy
- Broad Bandwidth
- Low Zero-drift

Operating Status Instructions

When power supply is normal and the primary current is within the specified measurement range, the secondary and primary currents are in proportional. If the primary current is over the specified measurement range, the transducers will be in overload mode, and the secondary and primary currents are not in proportional. The secondary and primary currents will return to be in proportional when the primary current recovers to the specified measurement range.

Connection system

1. Pin function definition of phoenix terminal

Pin No.	1 V+	2 V-	3 OUT	4 GND
Definition	+15V Supply	-15V Supply	I_Output	GND

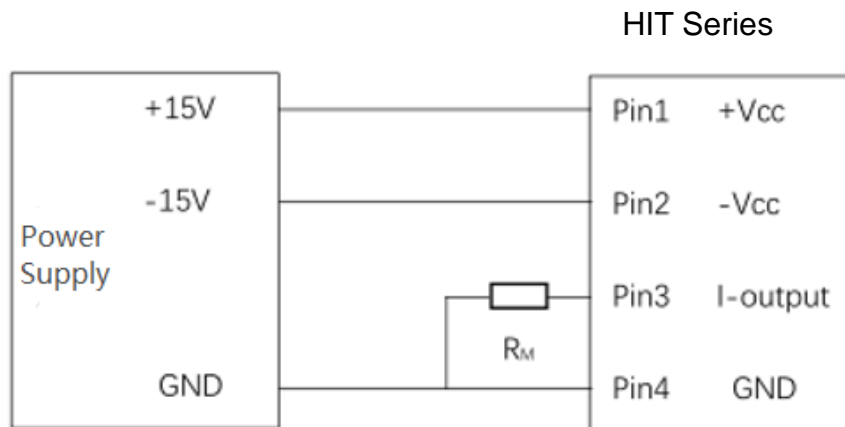

Test instruction:

The primary current I_P can be obtained by measuring the test current I_S flowing through R_M or the voltage U_R across R_M :

$$I_P = K_N * I_S = K_N * (U_R / R_M)$$



- High Accuracy
- Broad Bandwidth
- Low Zero-drift

Shenzhen Hangzhi Precision Electronics Co. Ltd.

Dimensions

Unit: mm

